

Room Cooling **ME-CDU**

Coolant Distribution Unit

In the acceleration towards an AI landscape, Mitsubishi Electric's ME-CDU is our new **Coolant Distribution Unit (CDU)** enabling an efficient, effective and reliable interface from liquid cooled servers to heat reuse or rejection - ensuring a continuous operation of the white space.

The **ME-CDU** is available in a single compact module, operating from 750kW to 1.2MW in capacity. Design for operating with the latest high density, high temperature servers, the equipment operates nominally with a Technology Cooling System (TCS) at 34°C / 24°C and a Facility Water System (FWS) at 20°C / 30°C - creating many opportunities for heat reclaim and reuse.

Provided with twin variable speed inverter pumps to give efficient operation and redundancy, the **ME-CDU** also has high quality 25-micron filters on the TCS, a touch screen display with advance control logic, and flexibility with the option for top or bottom connections. Along with the Mitsubishi Electric's vast portfolio of chillers, heat pumps, fan walls, CRACs and CRAHs, our new **ME-CDU** matches perfectly to your evolving requirements.



KEY FEATURES & BENEFITS:

- Available in a single compact module
- 4 capacities from 750kW to 1.2MW
- Engineered for stability, precision and continuity
- Efficient operation variable speed hydronic pumps in redundant configuration
- Advanced controls with touch screen interface and energy monitoring
- Inbuilt redundancy of pumps, temperature and pressure sensors and automatic refill tank to maintain pressures against micro-leaks
- Safe operation with 25-micron filter on the TCS and a 500-micron filter on the FWS
- Enhanced control capabilities, including water conductivity monitoring, pH and hardness sensing unique within this category combined with a newly designed HMI developed specifically for CDU applications
- Ready to integrate in hybrid cooling applications and heat reuse systems



ME-CDU		750	900	1100	1200
DIMENSIONS					
WIDTH (A)	mm	1,100	1,100	1,100	1,100
DEPTH (B)	mm	1,500	1,500	1,500	1,500
HEIGHT (H)	mm	2,100	2,100	2,100	2,100
PERFORMANCES¹					
COOLING CAPACITY	kW	750	900	1,100	1,200
EER	W/W	74.3	83.3	77.5	67.0
APPROACH DELTA T	K	4	4	4	4
PLANT SIDE (FWS)²					
FLUID		WATER	WATER	WATER	WATER
FLUID FLOW	m ³ /h	64.5	77.4	94.6	103.2
PRESSURE DROPS	kPa	80	83	87	95
CONNECTIONS	inch	4	4	6	6
FILTERS	No.	1	1	1	1
SERVER SIDE (TCS)					
FLUID		PROPELYNE GLYCOL 25%	PROPELYNE GLYCOL 25%	PROPELYNE GLYCOL 25%	PROPELYNE GLYCOL 25%
FLUID FLOW	m ³ /h	68.3	81.9	100.2	109.3
CONNECTIONS	inch	4	4	6	6
INTEGRATED PUMP(S) CONFIGURATION		1+1	1+1	1+1	1+1
FILTERS	No.	3	3	3	3
ELECTRICAL DATA					
POWER SUPPLY ³		400V / 3ph / 50Hz	400V / 3ph / 50Hz	400V / 3ph / 50Hz	400V / 3ph / 50Hz
MAX POWER CONSUMPTION	kW	15.0	17.0	22.5	26.0
PUMPS POWER INPUT @200 kPa Available Head	kW	10.1	10.8	14.2	17.9
PUMPS POWER INPUT @350 kPa Available Head	kW	13.4	17.4	21.5	25.9

Notes:

¹ Performance based on the following condition: Plant Side using water at 20/30°C; Server side using 25% propylene glycol at 34/24°C.

² Plant side pumps external to the CDU.

³ 60Hz power supply options available.

ME-CDU DIMENSIONS

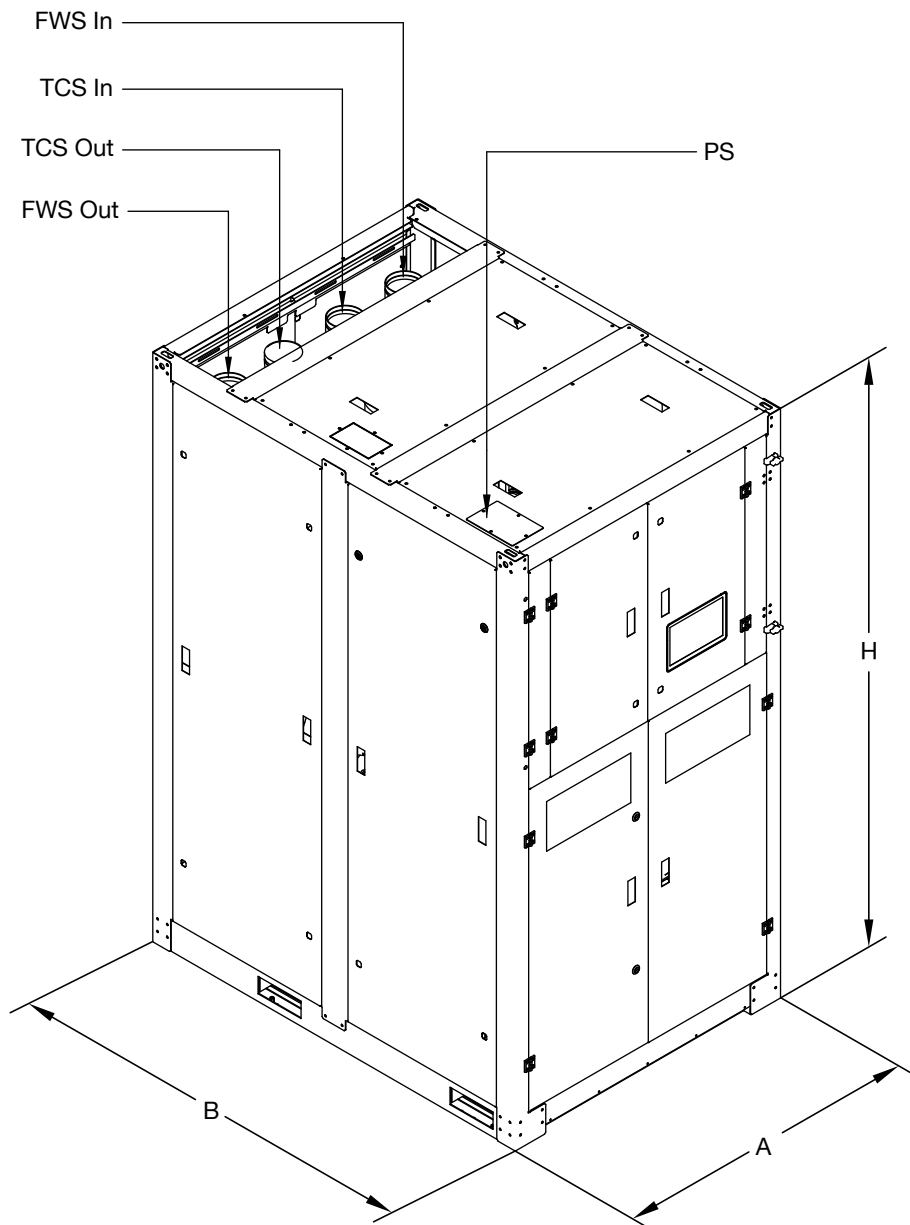

FWS In = Facility Water System Inlet

FWS Out = Facility Water System Out

TCS In = Technology Cooling System Inlet

TCS Out = Technology Cooling System Outlet

PS = Power Inlet

mitsubishi electric
HYDRONICS & IT COOLING SYSTEMS S.p.A.

Head Office:

Via Caduti di Cefalonia 1 - 36061 Bassano del Grappa (VI) - Italy

Tel (+39) 0424 509 500

www.melcohit.com